



AT.103

LINEAR ACTUATOR



- ✓ Installed on unwinding and rewinding stations
- ✓ ± 50 mm stroke
- ✓ 2000 N max thrust
- ✓ 3200 N max thrust with maxi version (Resmart system)
- ✓ Available with frontal flange, foot or rod ends bearing
- ✓ Available axial actuators or with gear box shifting

Linear actuators are generally used on unwinding and rewinding stations of compact machines to align the reel perfectly.

AT.103 guarantees a stroke of ± 50 mm and a max thrust of 2000 N; with the Maxi version, for those who require a superior thrust force, it can reach 3200 N.

Accordingly to the application it is available with frontal flange, foot or rod ends bearing fixing for an easy installation. Are also available axial actuators or with gear box shifting to reduce the space required or to increase the thrust force. The reed electronic limit switch are inserted in the slots of the steam and are easily accessible in case the operator needs to change the stroke of the actuator.

All parameters and set up of the actuators are easily managed by the operator using the MWG10.1 controller.

AT.103.A - RESMART

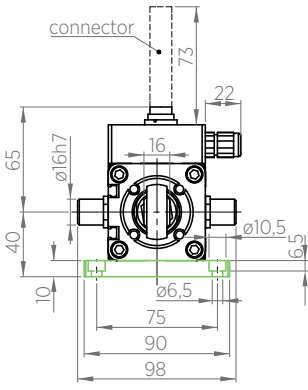

foot flange fixing

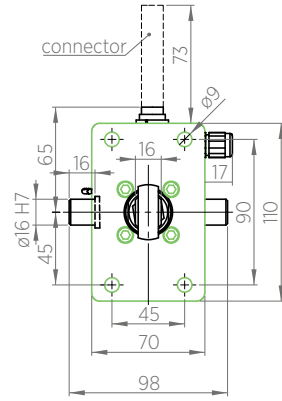

Frontal flange fixing

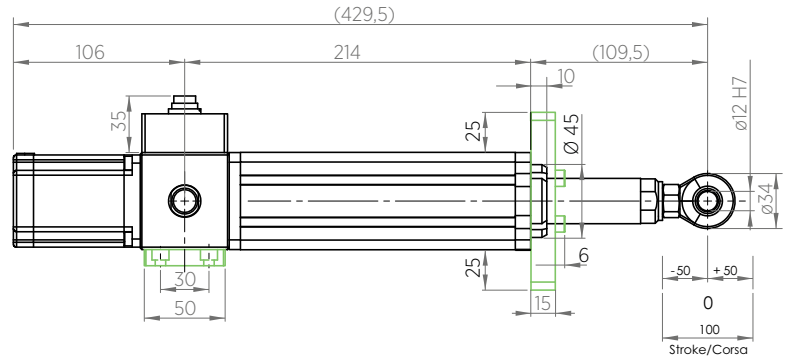

Stroke/Corsa

AT.103.A - SMARTMOTION

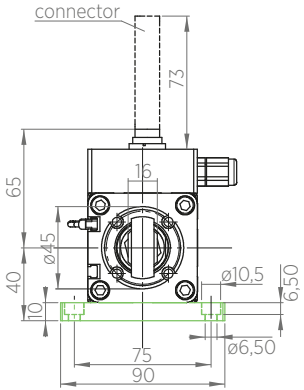

Rod ends bearing fixing

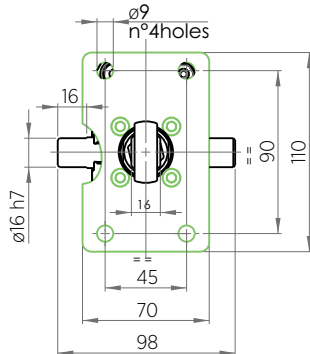

Frontal flange fixing

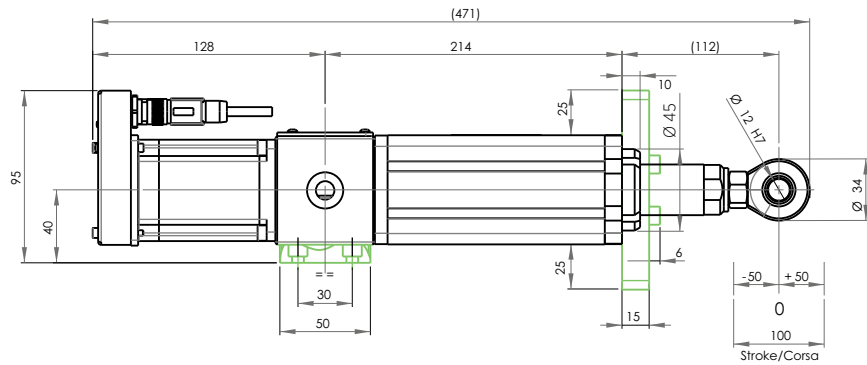

Stroke/Corsa

AT.103.R - RESMART

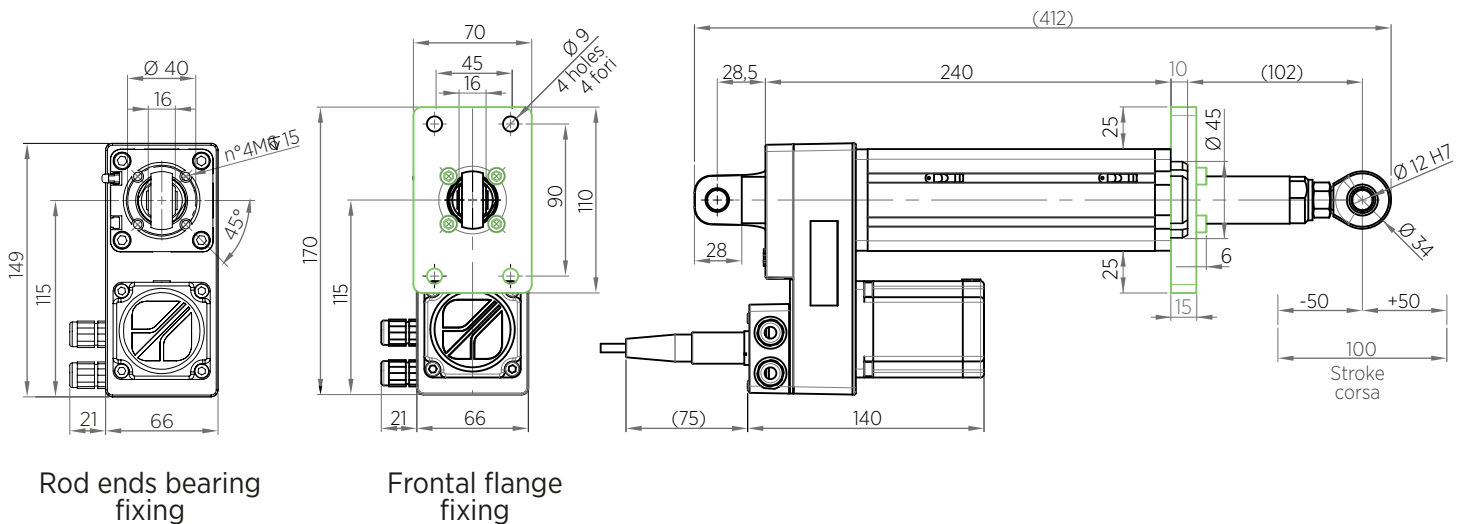

AT.103.R - SMARTMOTION

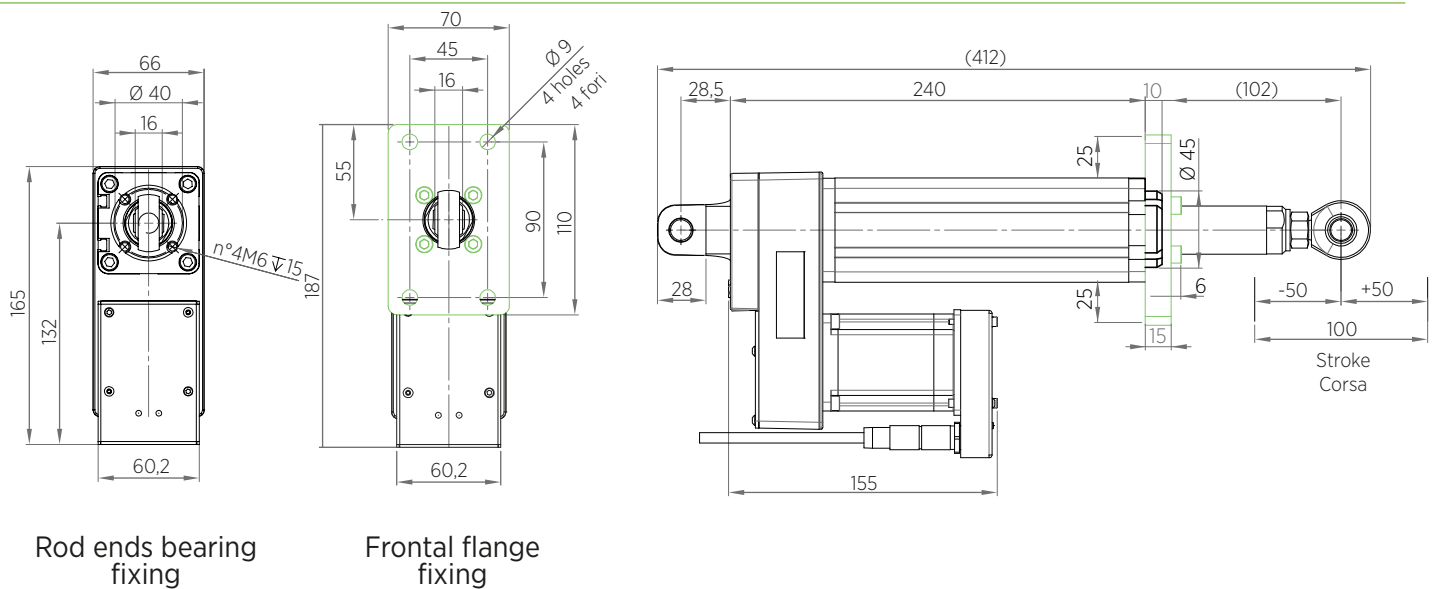

TECHNICAL CHARACTERISTICS

	AT.103.A	AT.103.A-MX*	AT.103.R	AT.103.R-MX*
Power supply	24 Vdc	24 Vdc	24 Vdc	24 Vdc
Power consumption	4 A	4 A	4 A	4 A
Stroke	± 50 mm	± 50 mm	± 50 mm	± 50 mm
Min speed	1 mm/s	1 mm/s	1 mm/s	1 mm/s
Max speed	45 (90**) mm/s	30 (60**) mm/s	37 (75**) mm/s	25 (50**) mm/s
Max thrust	1600 N	2600 N	2000 N	3200 N
Thrust at 20 mm/s	1400 N	2300 N	1800 N	2800 N
Working temperature	10÷50° C	10÷50° C	10÷50° C	10÷50° C
Protection class	IP40	IP40	IP40	IP40

*Only with Resmart system

**Max value reachable on request

Data are subject to technical change without notice



Re S.p.A.
via Firenze 3
20041 Bussero (MI) Italy

T +39 02 9524301
F +39 02 95038986
E info@re-spa.com

Assistenza tecnica
Technical support
T +39 02 952430.300
E support@re-spa.com

Assistenza commerciale
Sales support
T +39 02 952430.200
E sales@re-spa.com